

Z1752/...

Mat.: 1.2312/1080 N/mm<sup>2</sup>

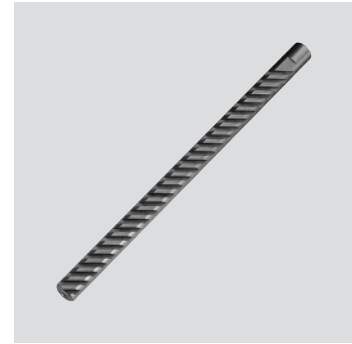

► Info

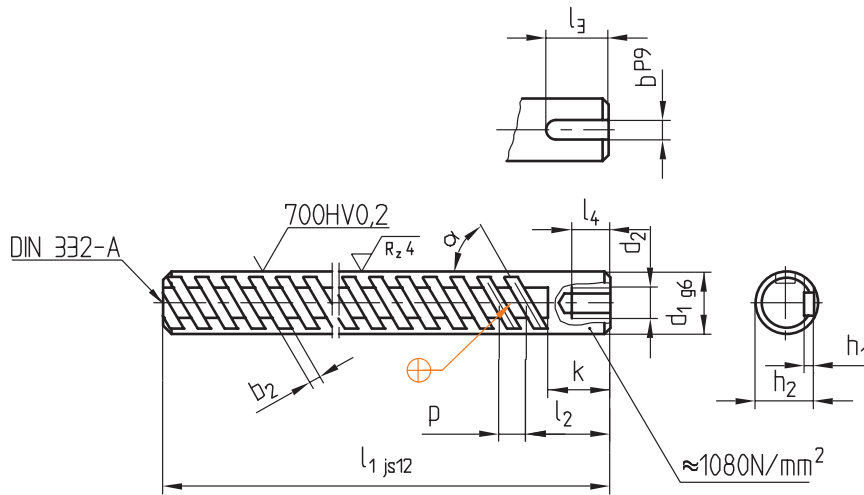

k	h <sub>2</sub>	h <sub>1</sub>	d <sub>2</sub>	l <sub>4</sub>	b	b <sub>2</sub>	p	l <sub>2</sub>	l <sub>3</sub>	d <sub>1</sub>	l <sub>1</sub>	α	Nr./No.
16	15	2,5	M 8	15	5	3	12	37	16	16	200	30	Z1752/16x200/30
											250		250/30
											315		315/30
16	15	2,5	M 8	15	5	3	8,48	29	16	16	160	45	160/45
											200		200/45
											250		250/45
20	22	3	M12	18	8	4	16	49	20	25	250	30	Z1752/25x250/30
											315		315/30
											400		400/30
											500		500/30
20	22	3	M12	18	8	4	11,31	40	20	25	200	45	200/45
											250		250/45
											315		315/45
											400		400/45

This is trial version  
www.adultpdf.com